

**Tire Coupling**  
**TIRE-N**  
**KWN 22210**

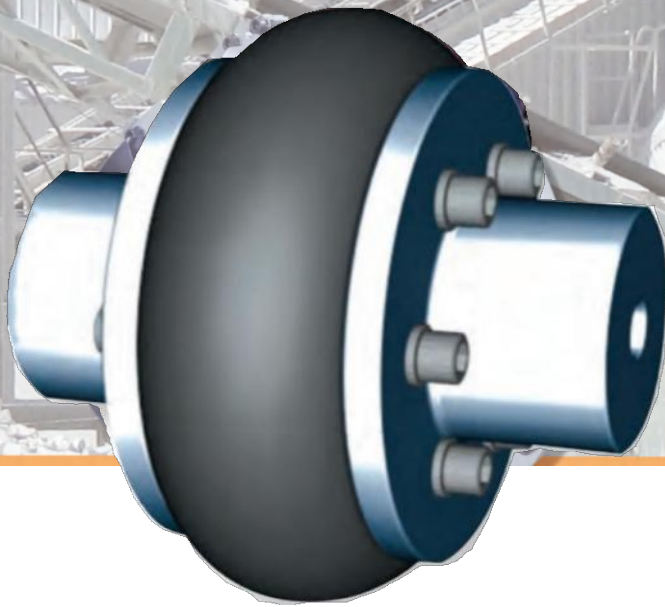

**Product | Engineering Services**  
**Maintenance**

## Merit and Feature

1. The Kudusworld tire coupling using natural compounds makes couplings suitable for use in most conditions.

2. Hand combinations of parallel, angular and axial displacements

Parallel displacement( $\Delta E$ ) : 1% of out dia

Angular displacement : with in  $2^\circ$

End float ( $\Delta d$ ) : within -10% and +3% the width of the coupling

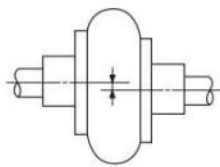

Paralled displacement

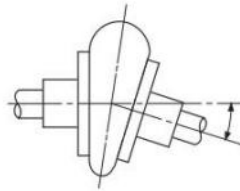

Angular displacement

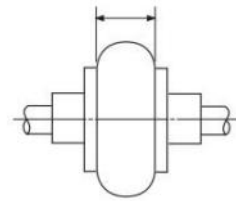

End float

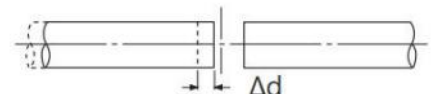
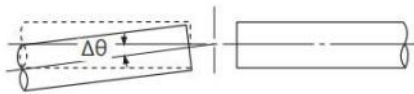
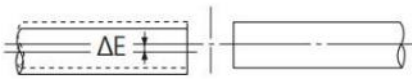

3. Quickly and easily installed and configured without any special tools. No lubrication is required after installation, and components do not need to be removed during inspection.

4. Effectively reduce torsional vibration and absorb impact load.

6. Damping reduce vibrations and torsional oscillations.

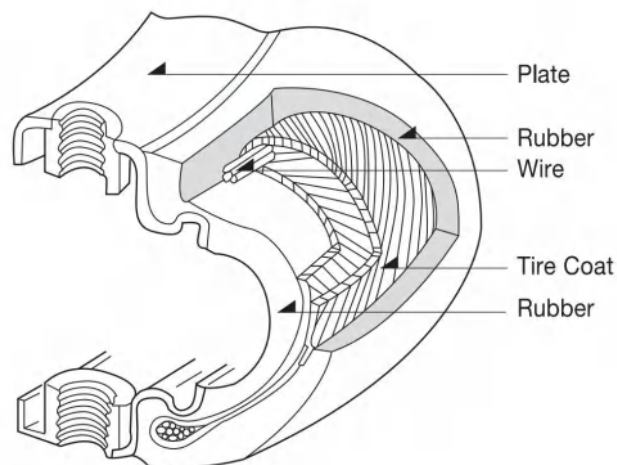

## Dimensions

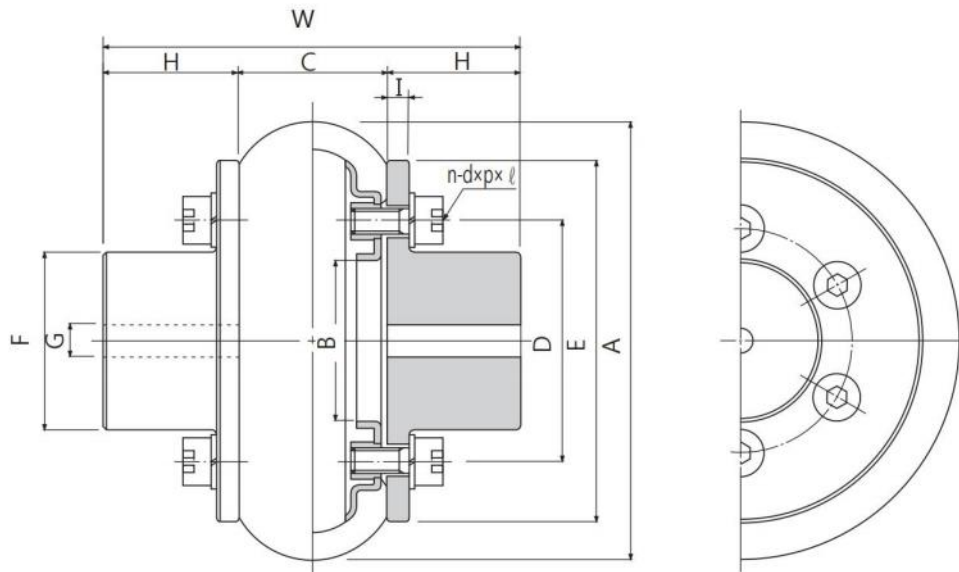

Size	Rating Torque (kg-m)	Max. (rpm)	Tire				Flange				G		W	Bolt 2 × n-d × p × l	GD <sup>2</sup> (kgf-cm <sup>2</sup> )	Weight (kg)
			A	B	C	D	E	F	H	I	Min. Bore	Max. Bore				
N-100	5	5000	100	35	37	50	82	36	28	6	8	22	93	2 × 6-M6 × 1.0 × 20	34.9	1.1
N-120	10	4500	120	45	39	65	106	48	35	6	10	28	109	2 × 6-M6 × 1.25 × 20	78.4	2.0
N-140	15	4200	140	52	45	75	118	55	44	7	24	35	133	2 × 6-M10 × 1.5 × 25	164.6	3.0
N-160	22	4000	160	62	51	85	132	65	53	8	24	42	157	2 × 6-M10 × 1.5 × 25	301.8	4.5
N-185	30	3600	185	74	58	100	154	77	60	10	34	48	178	2 × 6-M12 × 1.75 × 25	568.4	6.6
N-220	50	3200	220	84	67	112	180	89	69	12	34	55	205	2 × 6-M12 × 1.75 × 30	1,293.6	11.8
N-265	100	2600	265	112	82	140	214	117	94	14	40	75	270	2 × 6-M12 × 1.75 × 35	3,802.4	21.7
N-340	165	2100	340	142	106	180	272	150	120	18	44	95	346	2 × 6-M16 × 2.0 × 45	12,544	46.5
N-445	500	1600	455	190	139	236	344	202	160	25	54	128	459	2 × 6-M18 × 2.5 × 55	44,688	110
N-550	1000	1200	550	230	173	290	430	246	170	26	64	170	513	2 × 8-M24 × 3.0 × 70	125,440	187
N-700	2000	1000	700	310	220	370	544	326	220	26	84	220	660	2 × 12-M24 × 3.0 × 70	356,720	394





KUDOSWORLD CORPORATION

Website: [www.kwdcoupling.com](http://www.kwdcoupling.com)

Add: Orchard Summer Palace, No.209- 2 Qingnian Street, Shenhe  
District, Shenyang City, China 110016

Tel: 0086 (024) 31976438

Fax: 0086(024) 3197 6437